







▶▶▶▶we can now re-level much easier and quicker after the building has settled. We've invested heavily too in software controlled manufacturing. We find a data model that sets many parameters so that the products are absolutely reliable for the customer – it's a systems approach, a modern manufacturing approach.'

Public Relation Manager Désirée Schellerer confirms that the Bene way allies this technical systems approach with an unusual level of design sensitivity. 'Bene is an unusual company. We've always seen the importance of looking forward, to discover the next trend. It's vital for us to offer products that lead, and don't just follow. And of course it's not just about products, concepts are important. If you build a room you need a concept...

'You need to look at the whole area, with different zones. Maybe you need cellular offices or quick check-in spaces. You need a creative point of view.

'We've always been design-led with a systems process. Our design direction comes from Thomas Bene, and of course Laurids Ortner has been highly influential. He's an important Austrian architect, and for us a kind of chief designer and visionary. He's been a critical part of the Bene design

brand. The key point for Ortner is that he thinks like an architect – thinking of the whole space.'

R-Platform was designed by Johannes Scherr, who explains the system's ethos. 'I think of the office as a living space, as individual as its user's forms of work. Room shaping walls create closed or open areas, and determine the structure of the work environment. They shield visually and

acoustically, but their transparency encourages teamwork and interaction.

'R-Platform is an intelligent modular system for setting up double-glazed office and corridor walls. It's a sophisticated design that has great variety and flexibility – and sets new standards in technology, acoustics and upgradability.

'A key design feature is that R-Platform can be specified for different functions on▶▶▶▶▶

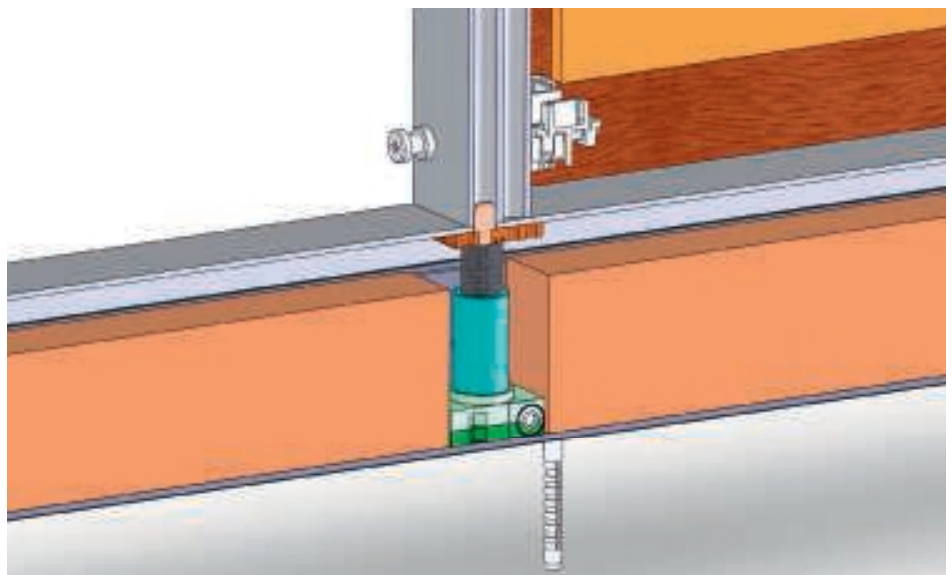



▶▶▶each side. The horizontal parts of the wall are the formally dominant design elements. It's extremely stable and ideal for organising the workspace with all sorts of hung cabinets, shelves and accessories. Panels are mounted individually into adjustable posts and can be taken out again, after the

assembly, at any time. The idea is that R-Platform is a reversible system that's easy to maintain, easy to access power and of course can be rearranged quickly and cost effectively.

'Of course, the double glazed corridor wall offers a host of design possibilities. It

can be completely transparent or as a combined glass/solid core wall. And just like the office wall, the corridor wall can have all sorts of different panels in various materials and segments – the choice is endless!'

Another important USP of the product is the Levelling Mechanism that enables levelling after installation, complete with fully loaded shelves/cupboards, whilst we'd also be amiss if we didn't mention that R-Platform can reach impressive acoustic insulation values up to 48 db Rw.

We left Vienna thinking about what we'd seen. This is a company that blends technical competence and design flair in an almost unique way in our sector. There's an organisational strength, a systems approach, but a strong streak of humanity, personality and character that's really appealing. The impressive new Vienna showroom stuns with its composition of PARCS elements and R-Platform roomsets in a way that somehow manages to combine seriousness and warmth. And R-Platform itself? 20 years in the Bene portfolio? Don't bet against it ●

